

*This image is an example only. The design may vary depending on the options selected.



D-TEC Flexliner FL-3-S Steel



Technical data | Technische gegevens | Technische Daten

FL-3-S Steel

Weight from Gewicht vanaf Gewicht ab	7.100 kg *
Kingpin weight Schoteldruk Sattellast	15.000 kg
Axle weight Asstel Achsaggregat	27.000 kg
Gross trailer weight Totaal toegestane massa Gesamt zulässige Masse	42.000 kg
Fifth wheel height Schotelhoogte Leergewicht ab	1.180 - 1.220 mm
3 Fixed axles 3 Starre assen 3 starre Achsen	9.000 kg
Axle inter distance Asafstand Achsabstand	1.410/1.310 mm
Material Chassis Materiaal Chassis Material Chassis	S700MC
Stepped chassis Getrapt chassis Gekröpft Chassis	80 mm
Foldable bumper Stootbalk opklapbaar Unterfahrschutz klappbar	Aluminium
Floor/side plate Bodem/zijplaat Boden/Seitenplatte	5 mm / 3 mm Hardox
Conical body Conische bak Konische Mulde	
Pneumatic door locks Pneumatische vergrendeling Pneumatische Zusatz Verriegelung	
Quality cover sheet Kwaliteit afdekkleed Qualität Plane	900 gr/m ²
Protection plate sheet Beschermplaat afdekkleed Schutzplatte Plane	

* According to / Volgens / nach DIN 70020

Options

Opties, Optionen

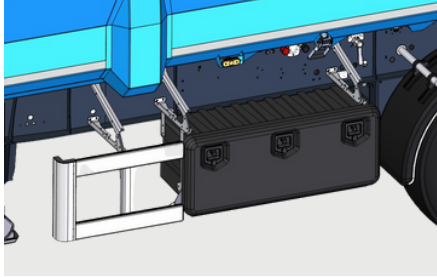

07-43

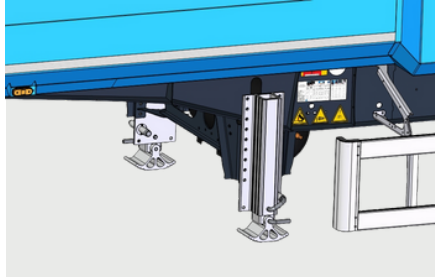

07-55

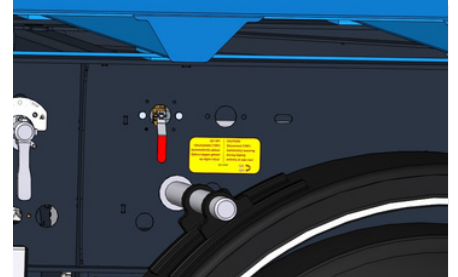

11-26



17-25



17-26

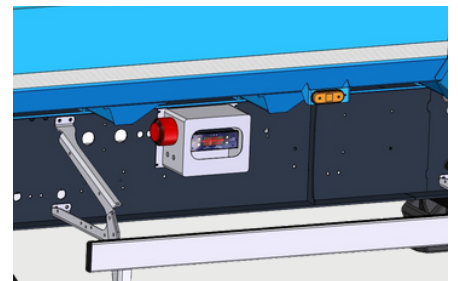

12-4

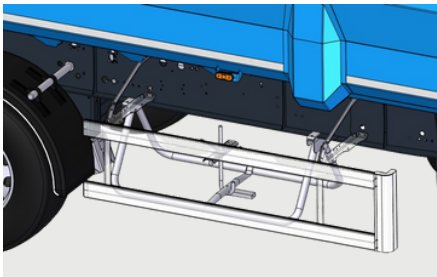

17-19

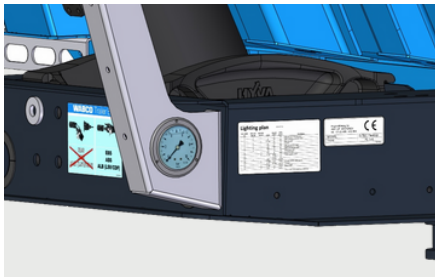

11-20

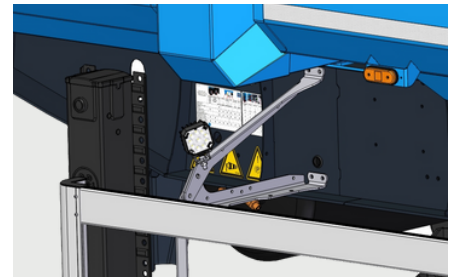

15-4-05

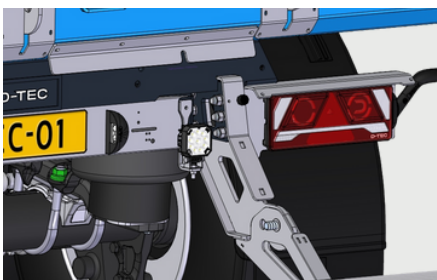

15-4-07

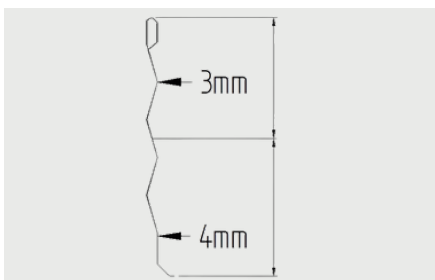

57-2-2

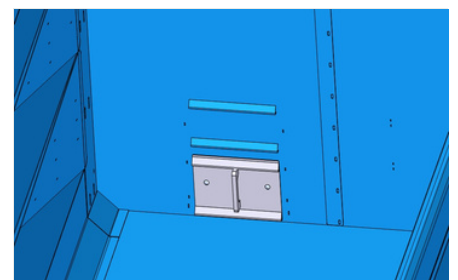

58-10-12

Specifications Specificaties, Specificaties, Spezifikationen

	 Options chassis	 Opties chassis	 Optionen Chassis
07-43/44	Plastic toolbox L / R	Kunststof gereedschapskist L / R	Kunststoff Werkzeugkasten L / R
07-52	Landing gear steel, liftcapacity 24t	Stalen steunpoten, tilvermogen 24t	Stützvorrichtung Stahl, Hublast 24t
07-55	Landing gear alloy, static capacity 20t	Aluminium Steunpoten, draagvermogen 20t	Stützvorrichtung Alu, Stützlast 20t
	BPW / VALX / Jost / SAF axles	BPW / VALX / Jost / SAF assen	BPW / VALX / Jost / SAF Achsen
11-FT-1	Axle 1 liftaxle automatic	As 1 liftas automatisch	Achse 1 Liftachse automatisch
11-FT-3	Axle 1 and 3 liftaxle automatic	As 1 en 3 liftas automatisch	Achse 1 und 3 Liftachse automatisch
11-FT-4	Axle 3 liftaxle automatic	As 3 liftas automatisch	Achse 3 Liftachse automatisch
11-2-17	Last axle steeringaxle	Laatste as naloop gestuurd	Letzte Achse nachlaufgelenkt
11-21	Aluminum airreservoir	Aluminium luchtketel	Aluminium Luftbehälter
11-20	Load pressure gauge	Balgdrukmeter	Belademanometer
11-26	Button for disabling the automatic lowering while tipping body	Knop om automatisch dalen uit te schakelen	Schalter zum Ausschalten der automatischen Absenkung
12-4	Weighing system	Weegstelsysteem	Wiegesystem
	Blocklights	Bloklampen	Mehrkammerleuchten
	3 Chamber rear lights	3-Kamer lampen	Runde Rückleuchten
13-14	Tyre Pressure monitoring	Bandenspannings bewaking	Reifendrucküberwachung
15-1	15-pin connector and 2x7 pin ISO N+S	15-polige stekker en 2x7 pin ISO-N+S	15-poliger Stecker und 2x7 pin ISO N+S
15-4-05	2x LED worklights on sideguards	2x Led werkampen op zijafscherming	2x LED Arbeitsscheinwerfer auf seitlichem Anfahrerschutz
15-4-07	2x LED worklights at the rear	2x Led werkampen achterop	2x LED Arbeitsscheinwerfer am Heck
15-25	Meeknipperende zijmarkering	Flashing side marker lights	Mitblinkende Seitenmarkierungsleuchten
17-7	Document tube	Documentenkoker	Dokubox
17-19	Sparewheelcarrier	Reservewieldrager	Reserveradträger
19-2/3	Sparewheel steel rim 385/65 or 385/55	Reservewiel staal 385/65 of 55	Reserverad Stahlfelge 385/65 oder 385/55
19-7-3	Alcoa Durabright alloy rims	Alcoa Durabright aluminium velgen	Alcoa Durabright aluminium Felgen
17-25	Ladder on the chassis	Ladder op het chassis	Anlegeleiter am Chassis
17-26	Carrier for broom, shovel etc on the chassis	Houder voor bezem, schop etc op het chassis	Halter für Besen, Schaufel, usw. am Chassis
17-NS-12	D-TEC mudflap blue	D-TEC spatlap blauw	Schmutzfänger blau
17-63	Mechanical tipping angle protection	Mechanische kiephoekbeveiliging	Mechanischer Kippwinkelschutz
19-55/65	Tyresize 385/55 or 385/65 R22,5	Bandenmaat 385/55 of 385/65 R22,5	Reifengröße 385/55 oder 385/65 R22,5
21-5	2 Wheelwedges	2 Wielkeggen	2 Radkeile
	Options body	Opties opbouw	Options Aufbau
52-1-1	Hardox body, inclined bulkhead, 57 m3	Hardox laadbak, schuin kopschot, 57 m3	Hardox Mulde, Schräge Stirnwand, 57 m3
52-1-2	Hardox body, inclined bulkhead, 49 m3	Hardox laadbak, schuin kopschot, 49 m3	Hardox Mulde, Schräge Stirnwand, 49 m3
07-28	A-Sign	A-bord	A-Schild
51-H	Tipping cylinder Hyva (190 or 250 bar)	Kiepcilinder Hyva (190 of 250 bar)	Kippzylinder Hyva (190 oder 250 bar)
51-E	Tipping cylinder Edbro (190 bar)	Kiepcilinder Edbro (190 bar)	Kippzylinder Edbro (190 bar)
59-6	Coil gutter and accessories	Coilgoot en toebehoren	Coilmulde und Zubehör
57-2-2	Thickness sidewalls 4mm for the lower section and 3mm for the upper section	Zijwanden 4mm onderin en 3mm bovenin	Seitenwandstärke 4mm unten und 3mm oben
58-6	One piece door	Ééndelige deur	Einteilige tür
58-1-4	Rear side without grainhatch	Achterkant zonder graanschuif	Rückwand ohne Schieber
60-00	Without cover sheet	Zonder afdekkleed	Ohne Abdeckplane
60-22	Cover sheetwith one dome, two sheetpoles and three straps.	Afdekkleed met één toog, twee kleeđuizen en drie spanbanden.	Abdeckplane mit ein Spriegel, zwei Planrohren und drei Zurrgurte.
60-26	Cover sheetwith one dome, two sheetpoles and quicklock system	Afdekkleed met één toog, twee kleeđuizen en snelversluit bevestiging.	Abdeckplane mit ein Spriegel, zwei Planrohren und Schnellverschluss.
56-3-6	Catwalk mounted on the chassis with one ladder	Bordes aan chassis met één ladder	Plattform mit einer Leiter an chassis montiert
59-3	To transport three different coil configurations: 1x 23t. 3x 8t. 4 x 6t.	Transport van coils in drie verschillende configuraties: 1x 23 t. 3x 8 t. 4 x 6t.	Zum Transport von drei verschiedenen Coil Konfigurationen: 1x 23t. 3x 8t. 4 x 6t.

Measurements

Afmetingen, Abmessungen

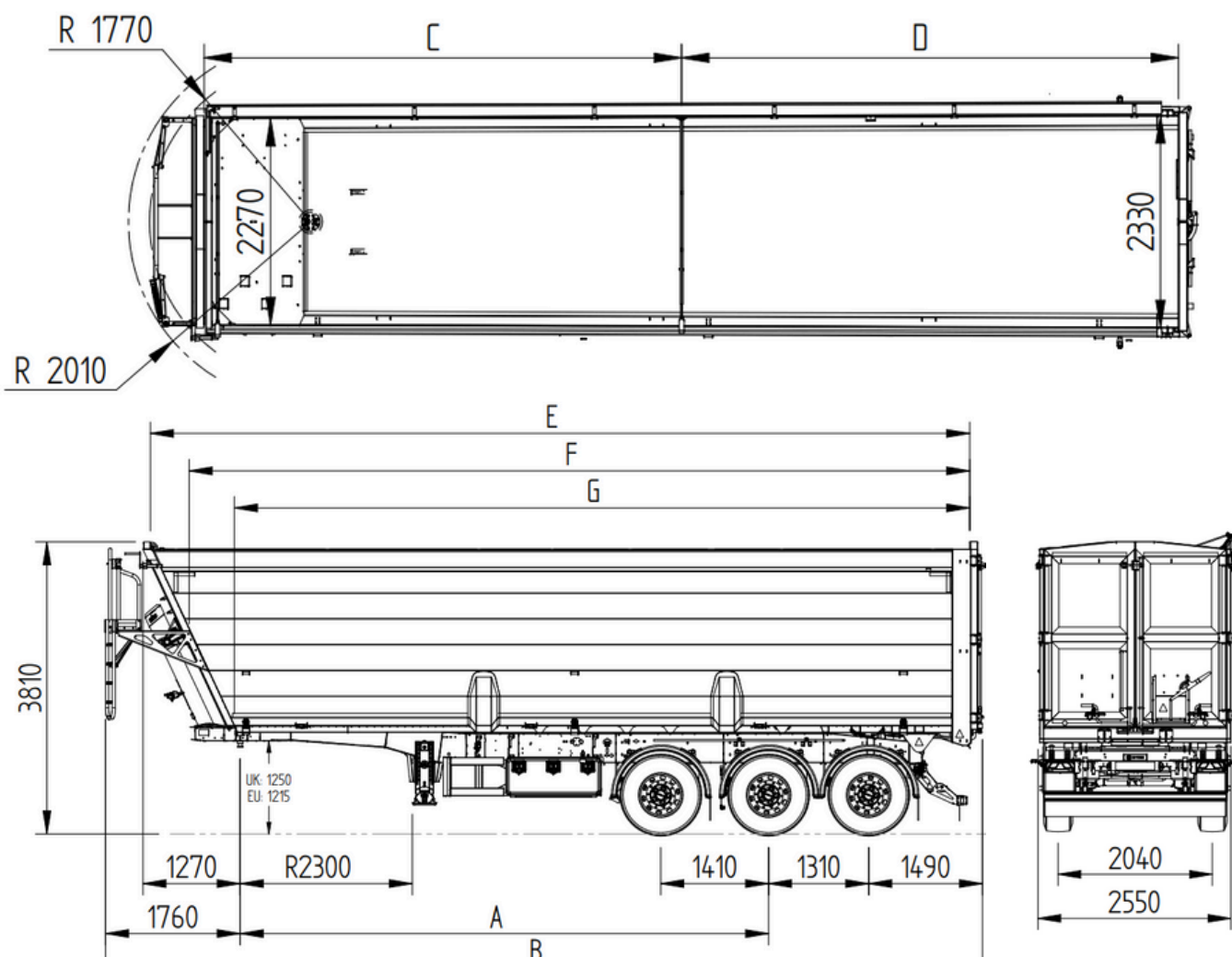

Dimensions in mm							
	A	B	C	D	E	F	G
[52_1_1] 57m ³	6920	11427	5226	5466	10690	10150	9620
[52_1_2] 49m ³	5620	10127	4816	4577	9390	8850	8320