

\*This image is an example only. The design may vary depending on the options selected.

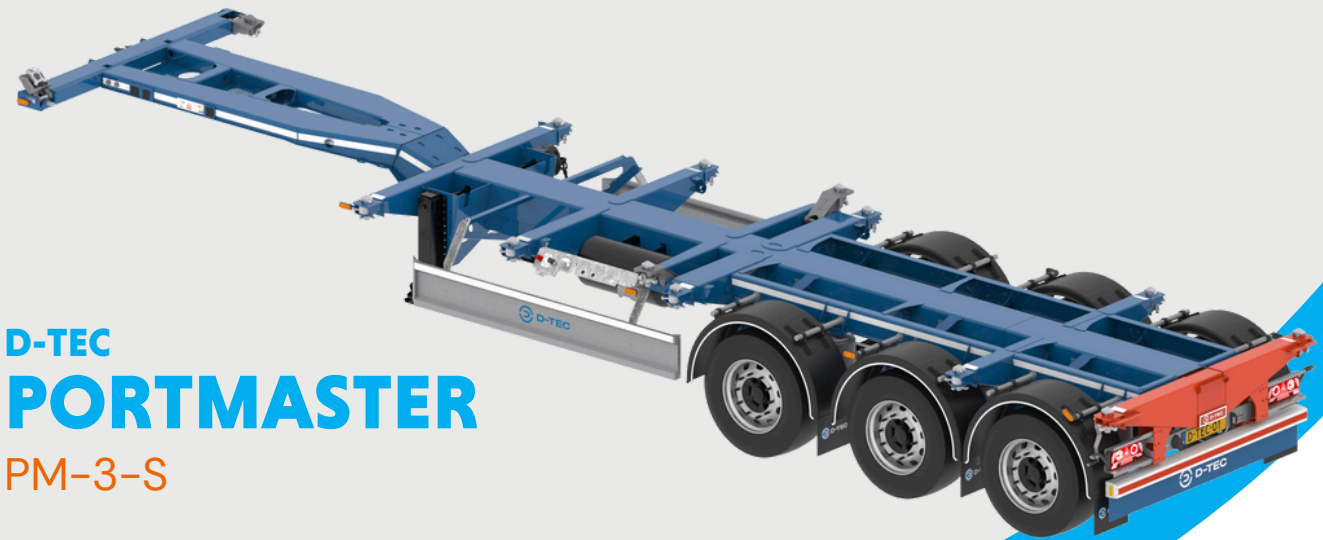

# D-TEC PORTMASTER

## PM-3-S



### Technical data | Technische gegevens | Technische Daten

### PM-3-S

Suitable for   Geschikt voor   Geeignet für	20 ft rear 20 ft central 30 ft 2x 20 ft 40 ft (HC) 45 ft (optional)
Kingpin weight   Schoteldruk   Sattellast	16.000 kg
Max. Axleload / axle   Maximale aslast per as   Max. Achslast pro Achse	9.000 kg
Gross trailer weight   Totaal toegestane massa   Gesamt zulässige Masse	43.000 kg
Empty weight from   Leeggewicht vanaf   Leergewicht ab	4.500 kg
Payload   Nuttig laadvermogen   Nutzlast	38.500 kg
Fifthwheel height   Schotelhoogte   Sattelhöhe	1.110 mm
Chassis height   Chassishoogte   Chassishöhe	1.110 mm
Tyresize   Bandenmaat   Reifengröße	385/55 R22,5
Electrical connectors   Elektrische aansluitingen   Elektrische Anschlüsse	1x 15 pin

# Options

## Opties, Optionen

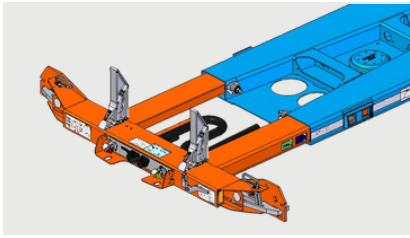

05-7

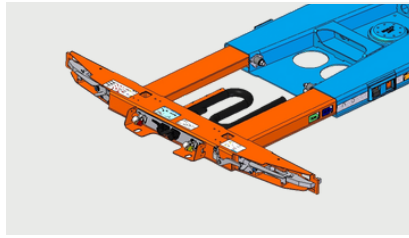

05-12

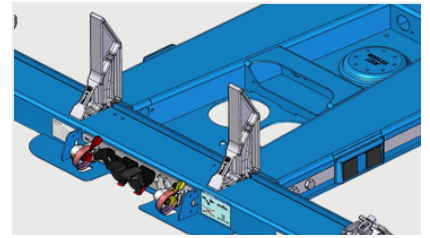

21-16

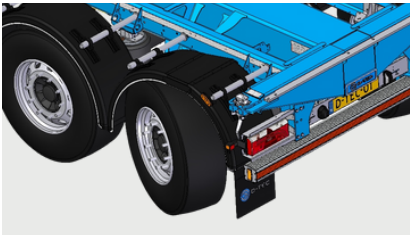

11-2-17

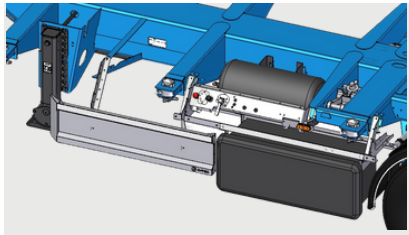

07-43

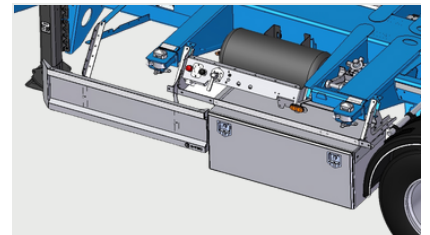

07-16

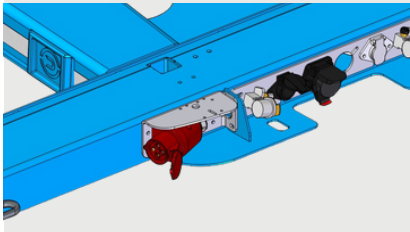

21-21

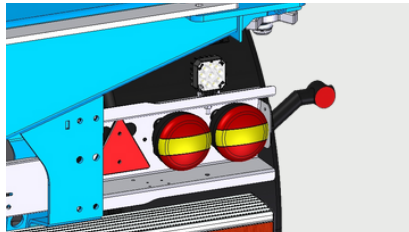

15-14

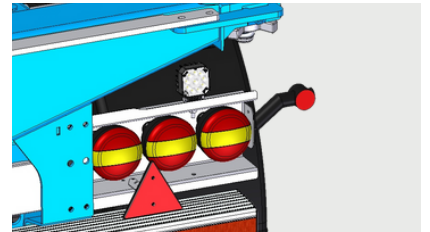

15-15

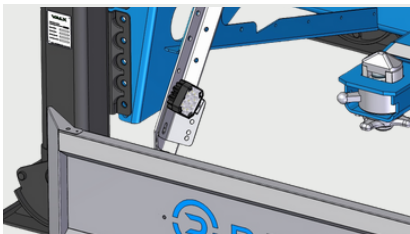

15-4-05

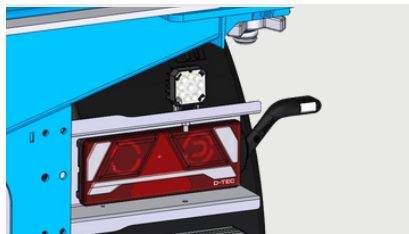

15-4-07

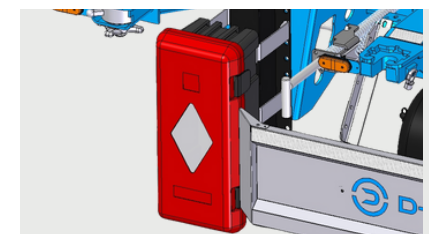

21-10



11-15

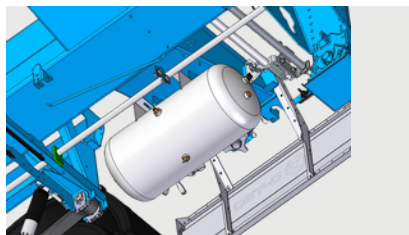

11-21

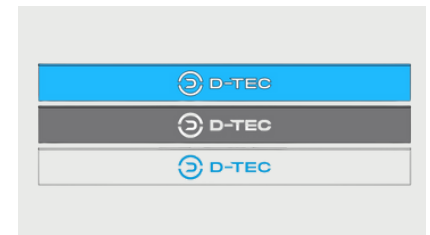

07-NS-12/13/14

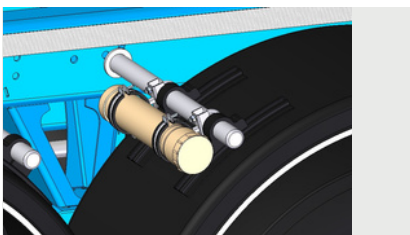

17-7

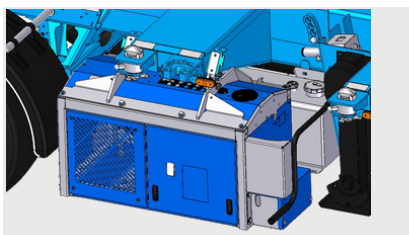

21-24

# Specifications

## Specificaties, Spezifikationen

	 <b>Comfort options</b>	 <b>Comfort opties</b>	 <b>Komfort Optionen</b>
11-4	VALX / JOST / SAF / BPW	VALX / JOST / SAF / BPW	VALX / JOST / SAF / BPW
11-2-17	Last axle steeringaxle	Laatste as naloop gestuurd	Letzte Achse nachlaufgelenkt
11-FT-1	Axle 1 liftaxle automatic	As 1 liftas automatisch	Achse 1 Liftachse automatisch
11-FT-3	Axle 1 and 3 liftaxle automatic	As 1 en 3 liftas automatisch	Achse 1 und 3 Liftachse automatisch
11-15	ATO Advanced Traction Optimization	ATO Advanced Traction Optimization	ATO Advanced Traction Optimization
11-18	Multifunction display	Multifunctioneel display	Multifunktionsdisplay
11-19	Lift axle control from cabin	Liftas besturing vanuit cabine	Liftachssteuerung elektrisch vom LKW
13-8	Test nipples for braking pressure L + R	Testnippels voor remdruk L+R	Prüfanschlüsse für Bremsdruck am Armaturenräger
13-9	Brake Light Power EBS	Remlichtvoeding EBS	EBS Notversorgung über Bremslicht
19-NS	Continental / Bridgestone / Michelin	Continental / Bridgestone / Michelin	Continental / Bridgestone / Michelin
19-7-3	Alcoa Durabright 6 alloy rims	Alcoa Durabright 6 alu velgen	Alcoa Durabright 6 alu Felgen
19-9-3	6 aluminum rims polished	6 aluminium velgen hoogglans	6 Aluminium Felgen poliert
19-55	Tyresize 385/55 R22,5	Bandenmaat 385/55R22,5	Reifengröße 385/55 R22,5
19-65	Tyresize 385/65 R22,5	Bandenmaat 385/65R22,5	Reifengröße 385/65 R22,5
09-1-1	Full schooping	Volledig schooperen	Völlig spritzverzinkt
09-1-2	Topside schooping	Bovenzijde schooperen	Oberseite spritzverzinkt
09-6	1-Layer coating 2K RAL 5015 / 9005	1 laag 2K natlak RAL 5015 / 9005	1 Schicht 2K RAL 5015 / 9005
09-6	2-Layer coating 2K customer choice	Spuiten 2-laags 2K natlak naar keuze	Lackieren 2 Schicht 2K nach Wahl
03-4-A	ADR Manufacturer certificate	ADR-fabrikantverklaring	ADR Herstellerbestätigung
25-NS-2	only NL	LZV uitgevoerd en gekeurd	nur für NL
05-7	Flexilock for 45' legal	Flexilock voor 45' legaal	Flexilock für 45' legal
05-12	Flexilock Reefer	Flexilock Reefer	Flexilock Reefer
05-23	45ft option	45ft optie	45ft Option
05-24	Stoßleiste	Stootstrip	Bumpstrip
07-3	Holder for kingpinlock	Kingpenslohouder	Halter für Königszapfenverriegelung
07-5	ADR sign at the rear	Gevaarlijke stoffen bord	Gefahrgutschild
07-11	Higher connectors at the front	Verhoogde stekkerplaat	Erhöhte Anschlüsse vorne
07-16	Stainless steel toolbox left	RVS gereedschapskist links	V2A Werkzeugkasten links
07-43	Plastic toolbox left	Kunststof gereedschapskist links	Kunststoff Werkzeugkasten links
07-28	A-Sign	A-bord	A-Schild
07-38	Ferry rings	Ferry ogen	2 Paar Zurringe für Fährenverladung
07-51	Length marking	Lengteborden	Längemarkierung
07-54	Rubber bump, left and right at the rear	Rubber stootblokken achterzijde	Gummipuffer Links und Rechts am Heck
07-NS-9	Steel plate at the rear, painted	Reclameplaat	Werbungstafel aus Stahl am Heck
07-NS-24	Landing gear Jost modul	Steunpoten Jost modul	Stützbeine Jost modul
11-21	Aluminum airreservoir	Aluminium luchtketel	Aluminium Luftbehälter
15-1	15-pin connector with 2x7p ISO N+S	15-polige stekker met 2x7p ISO-N+S	15-poligen Stecker mit 2x7p ISO N+S
15-14/15	4 or 6 round 3 chamber rear lights	4 of 6 ronde 3-kamer lampen	4 oder 6 runde Rückleuchten
15-16	All lights at the rear in LED	Alle lampen in led uitvoering	Komplette Beleuchtung in LED
15-4-05	LED worklights on sideguards	LED werkklampen op de zijafscherming	LED Arbeitsscheinwerfer auf seitlicher Anfahrtschutz
15-4-07	LED worklights at the rear	LED werkklampen achter	LED Arbeitsscheinwerfer am Heck
17-7	Document tube Plastic	Documenten koker uit plastic	Dokubox Kunststoff
17-19	Sparewheelcarrier	Reservewieldrager	Reserveradträger
17-22	Mudguards 2nd axle also antispray	Spatborden 2e as ook antispray	Flügel 2. Achse auch Antispray

# Specifications Specificaties, Spezifikationen

	 Options	 Opties	 Optionen
17-NS	D-TEC mudflap blue / black / white	D-TEC spatlap blauw / zwart / wit	Schmutzfänger blau / schwarz / weiß
21-16	Container stops	Containerstops	Containerführungen vorne
21-5	2 Wheelwedges	2 Wielkeggen	2 Radkeile
21-7	Hubodometer on the middle axle	Hubodometer op de middelste as	Hubodometer auf der Mittelachse
21-8	Kingpinlock	Kingpinslot	Königszapfenverriegelung
21-6	Holder with 6kg fire extinguisher	Houder met 6 kg brandblusser	Halter mit 6kg Feuerlöscher
21-10	Holder without 6kg fire extinguisher	Houder zonder 6 kg brandblusser	Halter ohne 6kg Feuerlöscher

# Measurements Afmetingen, Abmessungen

